

P06 & P09 - 2X2 Parabolic Troffer

Application

The P06 or P09 series 2X2 Parabolic Troffer is an efficient design for quality lighting in commercial and retail applications demanding the best in luminaire design. Designed for maximum visual comfort with high performance specular reflector and deep parabolic louvers, this luminaire is ideal for areas where CRT screens are used. For use in grid ceiling (NEMA Type G). Available in 2 and 3 lamp T5 or T8 configurations.

Construction

Fixture housing and ends are constructed from die formed steel, embossed for strength and uniformity. The heavy-duty ends attach to housing with tabs and screws. Fixture has integral EQ clips. Quick access plate for convenient power connections. All painted metal parts are pre-treated with a phosphate bonding process and painted with electrostatically applied high temperature baked white enamel for superior quality and durability.

Reflectors are constructed from highest quality specular on polished or white aluminum. Material form, fit and thickness meet or exceed all UL 1598 requirements. Computer assisted design provides maximum light output, uniform light distribution, rigid strength and ballast access without the use of tools. The durable surface is highly resistant to scratching and non-abrasive cleaning solutions, making the reflectors easy to clean.

Electrical

Energy saving and electronic Class P, CBM/ETL certified HPF ballast comply with Federal Energy Efficiency Standards; Underwriters Laboratories listed.

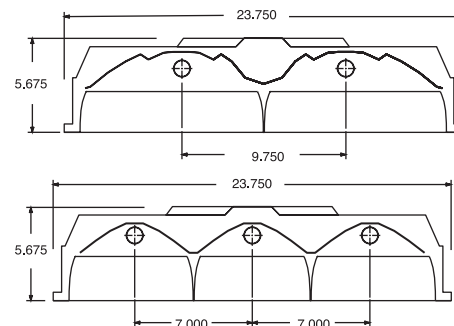
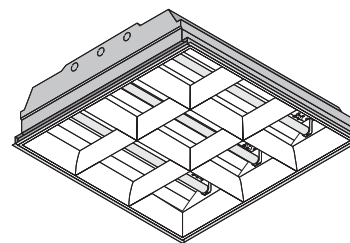
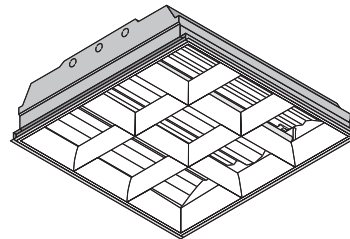

Industry Leaders in Customization + Lead Times for Over 25 Years



P06 & P09 - 2X2 Troffer Photometrics

reflect-a-light™

Coefficients of Utilization-Zonal Cavity Method Effective Floor Cavity Reflectance 0.20											
RC	80%				70%				50%		
RW	70%	50%	30%	10%	70%	50%	30%	10%	50%	30%	10%
0	78	78	78	78	76	76	76	76	73	73	73
1	73	71	69	67	72	70	68	66	67	66	64
2	69	65	61	59	67	63	61	58	61	59	57
3	64	59	55	52	63	58	54	51	56	53	50
4	60	53	49	46	58	53	49	45	51	48	45
5	55	48	44	40	54	48	43	40	47	43	40
6	52	44	39	36	50	44	39	36	43	39	35
7	48	40	36	32	47	40	35	32	39	35	32
8	45	37	32	29	44	36	32	29	36	31	28
9	41	34	29	26	41	33	29	25	33	28	25
10	39	31	26	23	38	31	26	23	30	26	23

Catalog Number:
P09-21722-SA-N

Lamps:
Two F17T8

Ballast:
Electronic 2-F32IS

Plane: 0-DEG 90-DEG
Spacing Criteria: 1.1 0.9
Efficiency: 65.4%
Photometric Certified by: Luminaire Testing Laboratory
Report No.: LTL01370

Coefficients of Utilization-Zonal Cavity Method Effective Floor Cavity Reflectance 0.20											
RC	80%				70%				50%		
RW	70%	50%	30%	10%	70%	50%	30%	10%	50%	30%	10%
0	72	72	72	72	71	71	71	71	67	67	67
1	68	66	64	62	66	64	63	61	62	60	59
2	63	60	56	54	62	58	56	53	56	54	52
3	59	54	50	47	58	53	49	47	51	48	46
4	55	49	44	41	53	48	44	41	46	43	40
5	50	44	39	36	49	43	39	35	42	38	35
6	47	40	35	31	46	39	35	31	38	34	31
7	43	36	31	28	42	35	31	27	34	30	27
8	40	32	27	24	39	32	27	24	31	27	24
9	36	29	24	21	36	28	24	21	28	24	21
10	34	26	21	18	33	26	21	18	25	21	18

Catalog Number:
P09-31722-SA-N

Lamps:
Three F17T8

Ballast:
Electronic 3-F32IS

Plane: 0-DEG 90-DEG
Spacing Criteria: 1.2 1.5
Efficiency: 60.7%
Photometric Certified by: Luminaire Testing Laboratory
Report No.: LTL01369

Fixture Ordering Guide

P Series	09 Cell	3 Lamps	17 Wattage	22 Length x Width	EA Material	N Ballast
--------------------	-------------------	-------------------	----------------------	-----------------------------	-----------------------	---------------------

Mounting Options
P - Grid Parabolic

Louver Options
06 - 6 Cell Louver
09 - 9 Cell Louver

No. of Lamps
2 - Two Lamps
3 - Three Lamps

Lamp Wattage
14 - 14 Watt T5
17 - 17 Watt T8
24 - 24 Watt T5
40 - 40 Watt T5
55 - 55 Watt T5

Fixture Size (Length x Width)
22 - 2x2

Material Type
EA - 95% Enhanced Aluminum
SA - 86% Specular Aluminum
WA - 91% White Aluminum
MA - 93% Micro Aluminum

Electronic Ballast Options
H - High Power
N - Normal Power
L - Low Power
4 - 480 Volt

Download catalog PDF's, IES files and cutsheets on our website.



www.usenergysciences.com
1.800.537.1629

US Energy Sciences
reflecting technology™