

P06 & P08 - 1X4 Parabolic Troffer

Application

The P06 or P08 series 1X4 Parabolic Troffer is an economical and efficient design for quality lighting in commercial and retail applications. This luminaire offers comfortable, controlled light output. For use in grid ceiling (NEMA Type G). Available in 1 and 2 lamp T5 or T8 configurations.

Construction

Fixture housing and ends are constructed from die formed steel, embossed for strength and uniformity. The heavy-duty ends attach to housing with tabs and screws. Fixture has integral EQ clips. Quick access plate for convenient power connections. All painted metal parts are pre-treated with a phosphate bonding process and painted with electrostatically applied high temperature baked white enamel for superior quality and durability.

Reflectors are constructed from highest quality specular on polished or white aluminum. Material form, fit and thickness meet or exceed all UL 1598 requirements. Computer assisted design provides maximum light output, uniform light distribution, rigid strength and ballast access without the use of tools. The durable surface is highly resistant to scratching and non-abrasive cleaning solutions, making the reflectors easy to clean.

Electrical

Energy saving and electronic Class P, CBM/ETL certified HPF ballast comply with Federal Energy Efficiency Standards; Underwriters Laboratories listed.

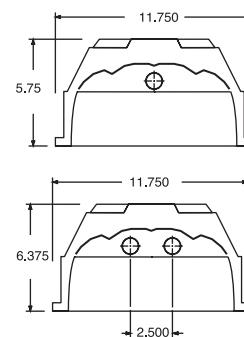
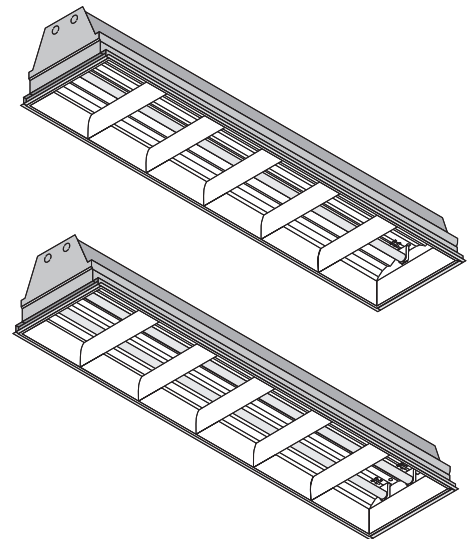

Industry Leaders in Customization + Lead Times for Over 25 Years



P06 & P08 - 1X4 Troffer Photometrics

reflect-a-light™

Coefficients of Utilization-Zonal Cavity Method Effective Floor Cavity Reflectance 0.20											
RC	80%				70%				50%		
RW	70%	50%	30%	10%	70%	50%	30%	10%	50%	30%	10%
0	86	86	86	86	84	84	84	84	80	80	80
1	81	78	76	74	79	76	74	72	73	72	70
2	75	71	67	64	73	69	66	63	67	64	62
3	70	64	59	56	68	63	59	55	61	57	54
4	65	58	52	48	63	57	52	48	55	51	47
5	60	52	46	42	58	51	46	42	50	45	41
6	55	47	41	37	54	46	41	37	45	40	36
7	51	42	36	32	50	41	36	32	40	36	32
8	47	38	32	28	46	37	32	28	36	31	28
9	43	34	28	24	42	33	28	24	33	28	24
10	40	31	26	22	39	30	25	22	30	25	21

Catalog Number:
P06-13214-SA-N

Lamps:
One F32T8

Ballast:
Electronic 1-F32IS

Plane: 0-DEG 90-DEG
Spacing Criteria: 1.2 0.8
Efficiency: 72.2%
Photometric Certified by: Luminaire Testing Laboratory
Report No.: LTL01388

Coefficients of Utilization-Zonal Cavity Method Effective Floor Cavity Reflectance 0.20											
RC	80%				70%				50%		
RW	70%	50%	30%	10%	70%	50%	30%	10%	50%	30%	10%
0	71	71	71	71	69	69	69	69	66	66	66
1	66	64	62	60	65	63	61	59	60	59	58
2	62	58	55	52	60	57	54	52	55	52	50
3	57	52	48	45	56	51	48	45	50	47	44
4	53	47	43	39	52	46	42	39	45	41	38
5	49	42	37	34	48	41	37	34	40	36	33
6	45	38	33	30	44	37	33	29	36	32	29
7	41	34	29	26	40	33	29	26	33	28	25
8	38	30	25	22	37	30	25	22	29	25	22
9	35	27	22	9	34	27	22	19	26	22	19
10	32	24	20	17	31	24	20	17	24	20	17

Catalog Number:
P08-23214-SA-N

Lamps:
Two F32T8

Ballast:
Electronic 2-F32IS

Plane: 0-DEG 90-DEG
Spacing Criteria: 1.2 1.5
Efficiency: 69.4%
Photometric Certified by: Luminaire Testing Laboratory
Report No.: LTL03782

Fixture Ordering Guide

P Series	06 Cell	2 Lamps	32 Wattage	14 Length x Width	EA Material	N Ballast
--------------------	-------------------	-------------------	----------------------	-----------------------------	-----------------------	---------------------

Mounting Options

P - Grid Parabolic

Louver Options

06 - 6 Cell Louver

08 - 8 Cell Louver

No. of Lamps

1 - One Lamp

2 - Two Lamps

Lamp Wattage

32 - 32 Watt T8

54 - 54 Watt T5

Fixture Size (Length x Width)

14 - 1x4

Material Type

EA - 95% Enhanced Aluminum

SA - 86% Specular Aluminum

WA - 91% White Aluminum

MA - 93% Micro Aluminum

Electronic Ballast Options

H - High Power

N - Normal Power

L - Low Power

4 - 480 Volt

Download catalog PDF's, IES files and cutsheets on our website.



www.usenergysciences.com
1.800.537.1629

US Energy Sciences

reflecting technology™